

Solar Converters Inc.
(Since 1994)

MANUAL
Model: BD-2 V2
Solar Converters Inc. - Rev. D

1.0 Application

When batteries age and/or spend too much time in a discharge or abused state, sulphite crystals can form on the battery plates, which impedes the flow of electricity and is the main cause of poor battery performance. This unit is a basic Battery Desulphators with advance control techniques. This unit emphasizes extremely low cost and premium performance.

Note: This unit operates in conjunction with a battery charger that is charging the battery to its nominal float voltage

2.0 Electrical Specifications

Base Model:	Battery Desulphator Version 2
Note:	Version 2 of the BD-2 increases the pulsed voltage which means that the pulse can get through higher impedances or larger battery strings and battery banks.
Nominal battery voltages (V)	12 - 48 V DC
Maximum Input (V)	63 V
Maximum Pulse Current(A)	10 Amps
Range of On/Off Control	0 V to 70 V Adjustable with Voltmeter and small screwdriver
Self Consumption	15 ma off, 50 ma on
Fuse	1 Amp thermal resettable

3.0 Basic Operation

Sulphite crystals form when the battery charge is reduced and/or the discharge/discharge cycles are not well suited for the battery. These sulphite crystals act as insulators to the flow of electricity in the battery, seriously degrading the capability of the battery to have electricity flow in it, reducing its charging and discharge capability.

This unit uses a sharp pulse of current forced into the battery suddenly to "jar" the sulphite crystals and cause internal resonance, both mechanical and electrical, to grind down the sulphite crystals that form so they be re-combined into the battery acid.

For increased performance, this unit precisely controls the magnitude of the sharp pulse of current, which is adjustable by the user. This adjustment is important as no 2 batteries are the same and no 2 battery set-ups are the same. As well, battery desulphators, as they work with current spikes, may interfere with equipment connected to the unit. This adjustment allows the user to tailor the both the current spike and at what voltage it is present.

4.0 Battery Connection

Using wire of sufficient gauge (#16 AWG or better), connect the red wire to the battery positive and the black wire to battery negative.

Note: In the event of reverse polarity an internal thermal resettable fuse will open to try to save the on board electronics. This fuse must cool down before the unit can be used again. Reversing polarity can potentially damage the unit.

Warning: If the BD-2 V2 is hooked up to a weak battery or a battery bank that has a high impedance the output pulse voltage could get very high. Make sure connections are secure and avoid direct contact with any of the battery connections.

5.0 User Adjustments

Turn on Voltage

Use a meter inserted into the 2 test points. Determine the voltage that you wish to operate the unit at. This is usually the battery float voltage less 0.5 V. The unit has a 1/20th scale factor so divide the voltage you wish to operate at or above by 20. This voltage (1/20th scale) is the setting of the V-on pot. Adjust the set pot to set the desired voltage calculated above. The unit will now operate only when the voltage is above this set voltage.

For example, a 12 V battery floats at 14 V. Thus the unit should operate at above 13.5 V (14 -0.5). Using the TP and GND setpoints and a digital multi- meter, adjust the V-On voltage set voltage using a small screwdriver to 0.65 V ($13.5 / 20 = 0.65$ V). It is factory set to 0.65 V.

Application Notes

For best results and performance, the unit should only supply its pulses when the battery voltage is at or near its float voltage. Some charging sources are better than others and batteries may be of different health to begin with.

1) New batteries or batteries that will still hold over 25 % charge.

No special care is required of the setup. The battery is sufficiently strong to tame the output voltage variations of almost any charger independent of its quality that would reasonably be used with a battery of that size. Attaching the desulphator will prevent sulphation of these batteries as they go through their usual charge/ discharge cycles.

2) Badly Sulphated Battery

If the battery is very sulphated i.e. it cannot hold much of a charge itself, extra care to recover the battery must be taken as typical lower quality charging sources like hardware store car battery chargers or standard PWM controllers will over voltage the battery as the battery does not have the capacity to "tame" the higher voltage pulses these units put out with no or very poor battery attached causing other failures while it is being desulphated.

In this case, make a coil of wire by wrapping 10 turns of the wire around your hand and use this coiled wire to connect the dead battery to a good battery that has a charge controller attached to it. Connect the desulphators to the bad battery.

The wire coil forms an inductor which will block the pulses from going into the good battery so it goes into the poor battery, and the good battery with its charger will keep the bad battery from being over voltage or damaged by the voltage wide variations of a lower quality charger source.

If the charger has a clean DC output (very little ripple) regulated to the float charge voltage like a DC power supply or one of Solar Converters Inc. MPPT charge controllers, the desulphators and battery can be directly connected without the need for an additional battery to tame the charger.

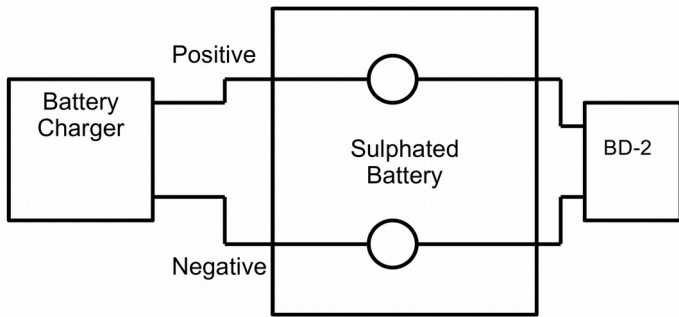

Normal Hookup

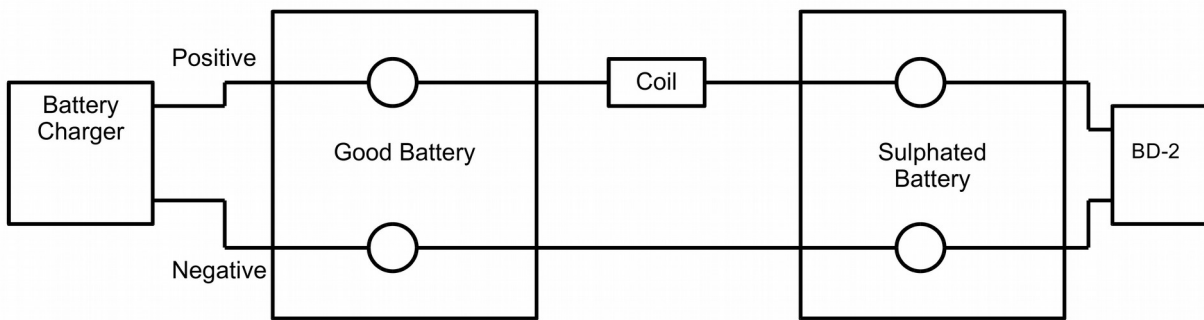

Example of desulphating badly sulphated battery.

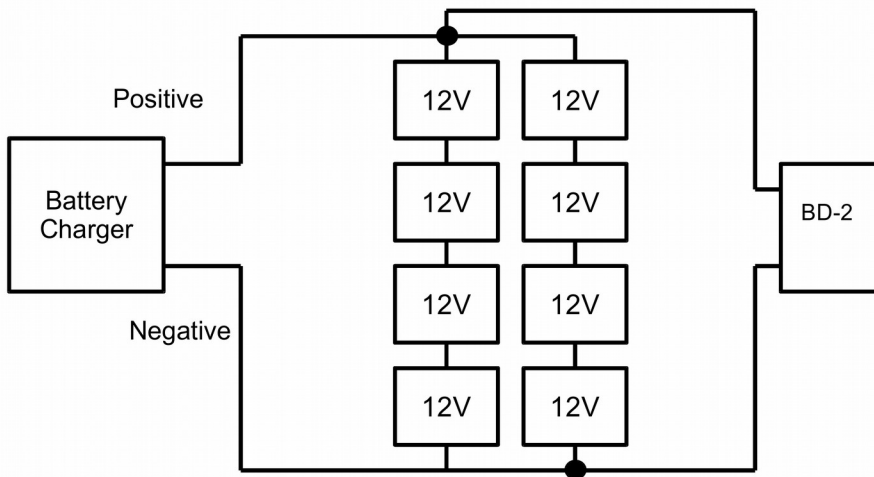

Attach BD-2 to opposite "corners" of the battery bank so that the pulse has to travel through the entire bank.

Example of desulphating multiple cell banks

WARRANTY

The product is warranted to be free from defects in material and workmanship for a period of one (1) year from the date of purchase by a retail customer. The purchase date must be evidenced by a valid and original sales receipt. In lieu of sales receipt, factory will use code date on its label. Removal of the Solar Converters Inc. label or serial number will void the warranty.

Product liability, except where mandated by law, is limited to repair or replacement at the manufacturer's discretion. No specific claim of merchantability or use shall be assumed or implied beyond what is printed on the manufacturers printed literature. No liability shall exist from circumstances arising from the inability to use the product, or its inappropriateness for any specific purpose or actual use, or consequences thereof for any purpose. **It is the user's responsibility to determine the suitability of the product for any particular use.** Solar Converters Inc. shall not be liable for any damages or any kind including without limitation, special, incidental or consequential obligations and liabilities of Solar Converters Inc. and the remedies of Buyer set forth herein shall be Solar Converters Inc. sole and exclusive liability.

Failure to provide a safe and correct installation, safe operation, or care for the product will void the warranty. Personal safety, and compatibility with any other equipment is the ultimate responsibility of the end user. Any returned product that shows significant evidence of abuse may not be covered by this warranty. Installation must be performed by a person with qualification to insure safe and effective operation and the installation thereof certifies that the installer has the technical qualifications to do so.

Solar Converters Inc. cannot guarantee the compatibility of its products with other components used in conjunction with Solar Converters Inc. products, including, but not limited to, solar modules, batteries, and system interconnects, and such loads as inverters, transmitters and other loads which produce "noise" or electromagnetic interference, in excess of the levels to which Solar Converters Inc. products are compatible. Solar Converters Inc. shall not assume responsibility for any damages to any system components used in conjunction with Solar Converters Inc. products nor for claims for personal injury or property damage resulting from the use of Solar Converters Inc. products or the improper operation thereof or consequential damages arising from the products or use of the products.

The warranties set forth herein are Solar Converters Inc. sole and exclusive warranties for or relating to the goods. Seller neither makes nor assumes any warranty or merchantability, any warranty fitness for any particular purpose, or any other warranty of any kind, express, implied or statutory. Solar Converters Inc. neither assumes nor authorizes any person or entity to assume for it any other liability or obligation in connection with the sale or use of the goods, and there are no oral agreements or warranties collateral to or affecting the sale of the goods.

WARRANTY CLAIM PROCEDURE

In the event of product failure, follow this warranty claim procedure.

1. Make sure the problem you are having is actually due to the suspected product and not some other part of the system. You may call technical support for advanced troubleshooting assistance.
2. If you determine that a Solar Converters Inc. product is actually defective, describe on paper, in detail the exact nature of the failure.
3. The product must be accompanied by proof of the date of purchase satisfactory to Solar Converters Inc.
4. Return the product and description to the business office address, along with your address and a daytime phone number. Purchasers must prepay all delivery costs or shipping charges as well as any other charges encountered, in shipping any defective Solar Converters Inc. product under this warranty policy. **No shipment will be accepted Freight Collect.**
5. Any return shipment from Solar Converters Inc. will be via Canada Post. Foreign shipments will ship best way. Special shipping arrangements are available at the customer's expense.